

2018 Rules & Regulations

Rules may be changed / amended by IMWA at any time.

The following are rules for the Illiana Mini Wedge Association. Membership in the IMWA shall be \$20.00 per year. Track Membership is also required at all the IMWA tracks. Membership applications can be obtained by calling 765-807-5002 or request your copy by email at Michael@IndianaDirtRacing.com

Section 1 – Car

- Wheelbase 45" – 49". Maximum width of the outside of the tire is 49". There are to be no roofs, sail panels. A maximum of a 3 inch spoiler will be allowed. Spoiler side's maximum height will be 3 inches from deck and 5 inches long.
- All karts must be constructed of steel tubing with a complete 6-point roll cage including adequate side protection. Cages must be a minimum of .065 x 1" steel tubing welded to the frame.
- The engine must be located behind the driver's seat. No part of the engine can be located beside the seat.
- Floor pans are required to be made of steel or minimum .040" aluminum. The floor pans are to be securely bolted or riveted to the frame. The length of the floor pan must go from the center of the seat to the front of the frame going past the driver's pedals.
- All karts must have a fully wedge Late Model appearing body. No open fenders will be allowed. There must be at least 4" of body behind the rear wheels. There will be no covered or enclosed motors all motors will remain completely visible at all times. See Body Drawings for more information.
- Tires must be a Hoosier (15600 "11 inches tall" or 15500 "10-1/2 inch tall") FK Compound. No grooving or sipping of the tires. No treating or soaking of tires. Tires must durometer 50, any tire that durometer is 48 or less will be deemed has treated and will result in a 12-month suspension.
- Rim width cannot be any wider than 6-1/2" wide and must be at least 6" Tall.
- Axle must be a Steel Axle and a minimum of 3/16" Wall Thickness.
- No suspension will be allowed. This includes springs, shocks, rubbers, torsion bars and any other type of dampening devise.
- Rear deck height cannot exceed a maximum of 24" from the ground and a minimum of 20" high from the ground.
- Body must be constructed of .040" aluminum. Plastic may be used for nose, fenders and trim.
- Kart must weigh no less than 335 lbs. with driver after the race. When tracks split the class by age they must split it by 5-9 and 10-14 years old. The 10-14 year old kids must weigh in no less than 375 lbs with driver after the race. (IMWA Tracks can chose to weigh in before or after the race.
- We highly encourage the doors and quarter panels to be wider than the track with at the bottom of the doors and quarters to help prevent "Wheel Hop".
- At least one vertical door bar must be welded on each side of the driver running from the main rail to side crash bars for driver protection. See rear side view drawing for more details.
- Front and rear bumpers must be mounted at all times. Front and rear bumpers must have at least a 6" tall hoop.
- Front and rear down tubes are mandatory for driver's protection.
- All tubing on main roll cage must be at least .065" wall tubing.
- Driver's seat must be mounted in four locations (4-Bolts)

- Two door numbers must be present with a minimum of 12".
- Must at all times have two return springs.
- Kill switch must be mounted on the deck visible to officials.
- Any weight mounted on the kart must be painted white with the drivers name and number on the weight. Weight must be mounted by at least a ½" bolt. Any weight lost during an event will result of a two week suspension.
- 5-Point harness system is mandatory. All harness must have a SFI Rated patch.
- All karts must have two triangle type side window nets attached to the roll bar one on each side of the driver.
- If you run the Butlerbuilt Full Containment seat you are not required to run a window net.

Section 2 – Engine

- Only two engines will be allowed. Item# 69730 and Item#60363, both from Harbor Freight.
- 6.5 HP (212cc) OHV Predator Engine will be the only engine allowed.
- Engine must remain stock.

You can disconnect the governor.

You cannot alter the exhaust in anyway.

You can change the spark plug.

You can disconnect the low oil sensor.

You can run an ARC Air Cleaner

You can change jets.

- Noram "Magnum" Premier clutch is allowed in 2018.
- MAX-Torque clutch is allowed in 2018.
- You can run 12, 13 or 14 tooth Clutches. (This is to help decrease our rear axle gear for more ground clearance.)
- In the event the age groups are split up, the 5-9 year old group will run the green restrictor plate.
- Engine claim is set to \$100, anyone finishing the feature can claim any driver at any time. Money must be in the hand of a race director no more than 10 minutes after the checkered flag. An IMWA official can also swap a motor at any time. This claim is the engine only, that does not include the Carburetor, Clutch, Chain Guard or Air Cleaner.
- The mission is to provide children a safe and competitive series to teach them the fundamentals, sportsmanship and completeness needed to grow into the sport as a young adult. Please keep in mind the Engine claim is to give every child the opportunity to compete without the worry of their family not being able to afford it or their family doesn't "cheat" enough to be competitive.

Section 3 – Race Rules

- All drivers must be accompanied by a parent or legal guardian. Unless you are appointed his / her legal guardian, by law, you cannot sign a release form for them. Therefore they cannot race. Any exception to this rule cannot be made by an IMWA official and must be brought before the track's management or track's insurance carrier for a decision.
- All cars will be lined up according to their pill draw. Failure to draw a pill before the lineup is turned into track officials. This will result in the driver starting at the tail of the race.
- Arguing about scoring or judgment calls will not be tolerated. Confrontations / arguments with IMWA Officials, track officials or another parent can result in a minimal suspension of 2-weeks from all IMWA sanctioned tracks.
- The scoring tower is off limits to drivers and anyone who is not a track staff member.
- Any parent, driver, or member of any team involved in any type of confrontation with anyone at the track will result in a suspension of driver and parent or legal guardian for at least two weeks from all IMWA events.
- Age limit is 5-14 years of age. You must provide a copy of your birth certificate before your membership can be provided.

- There will be NO WARNINGS given out for bad behavior such as; No throwing a fit on the racetrack or pit area NO jumping on the track officials, IMWA officials, scorers, flagman or track owner. No going to another pit to argue this includes driver, crew and anyone with a Mini Wedge.

Section 4 – Driver Personal Safety

- All drivers must wear an approved SFI – 1 certified or SFI13 – 2A/1 Fire Suit. SFI certification patch shall be required on fire suit.
- A Full Face helmet will be mandatory at all tracks and all IMWA events.
- All drivers must wear a neck brace.
- All drivers must wear arm restraints.
- All drivers must wear a closed toe shoe.
- Fireproof gloves are mandatory at all IMWA events.

Section 5 – Body Drawing and Specs

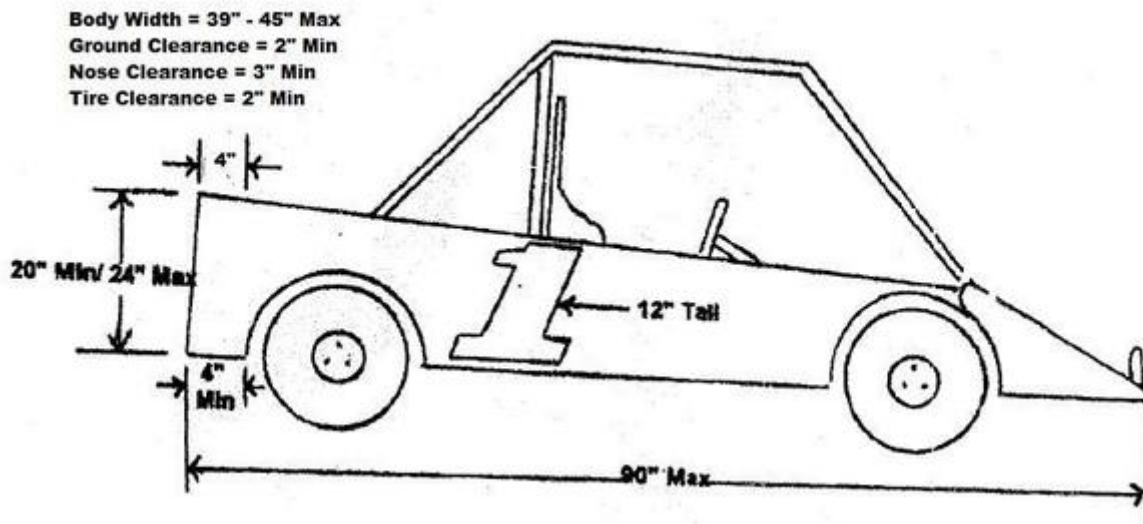

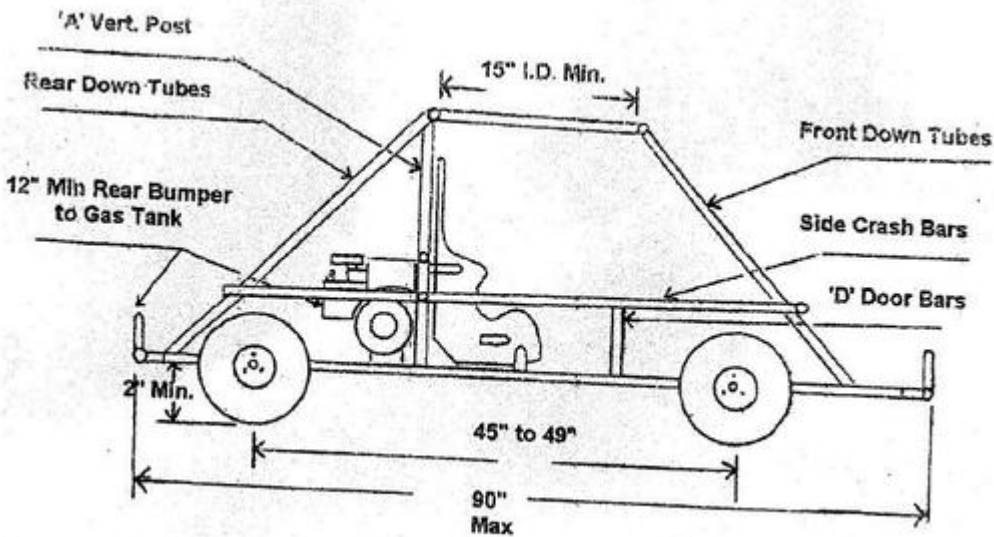
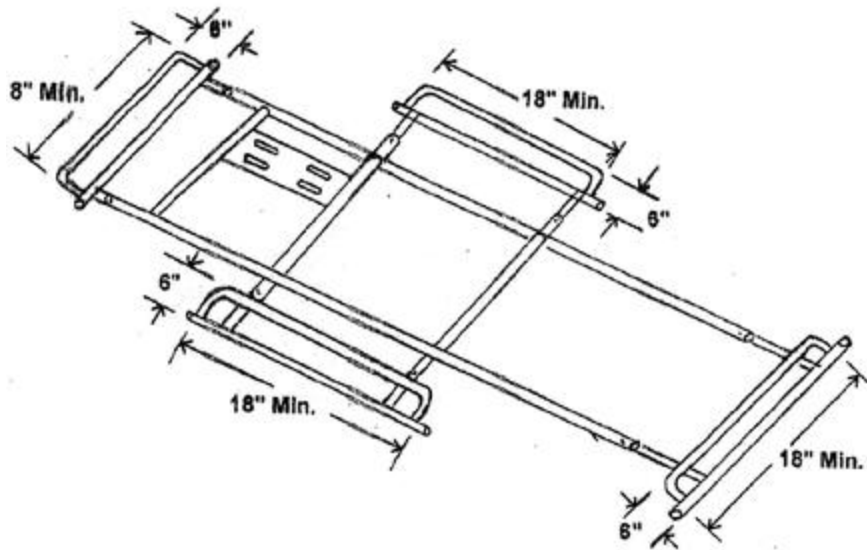

Section 6 – Point System

- 2018 point season begins on January 1, 2018.
- Top-30 in points will receive awards at year end banquet or final race.
- Points will be counted for 5-9 year old drivers and also for 10-14 year old drivers. Meaning we will have a champion in both age groups regardless if the tracks are able to split the class. The highest finishing 5-9 year old will be scored 20 points and the highest finishing 10-14 year old will be also scored 20 points.
- Drivers must be a Member of the IMWA to be eligible.
- All ties will be broken by using the greatest number of 1st place finishes during the season. If a tie still exists, the number of 2nd, 3rd, etc. will be used in the same manner, until the tie is broken

Section 7 – Race Procedure

- Cautions will be thrown when a driver spins out and is stopped on the track.
- Caution will be thrown when a driver drives off the track and is stuck.
- The caution car (judgement call) will be put to the tail.
- Two cautions and the driver will be black flagged for that event.
- The black flag will be thrown when a driver is driving rough, this is a judgement call and cannot be argued.
- The class will be split into two classes when the car count allows. 5 – 9 Year old and 10 – 14 Year old
- Races will be decided on by a Pill Draw.
- Top 3 will receive a trophy at the end of the night in each class.
- Top 3 must report to tech area.